

# Dyna\_Pro

Single-seat

**NOVAH**<sup>®</sup>

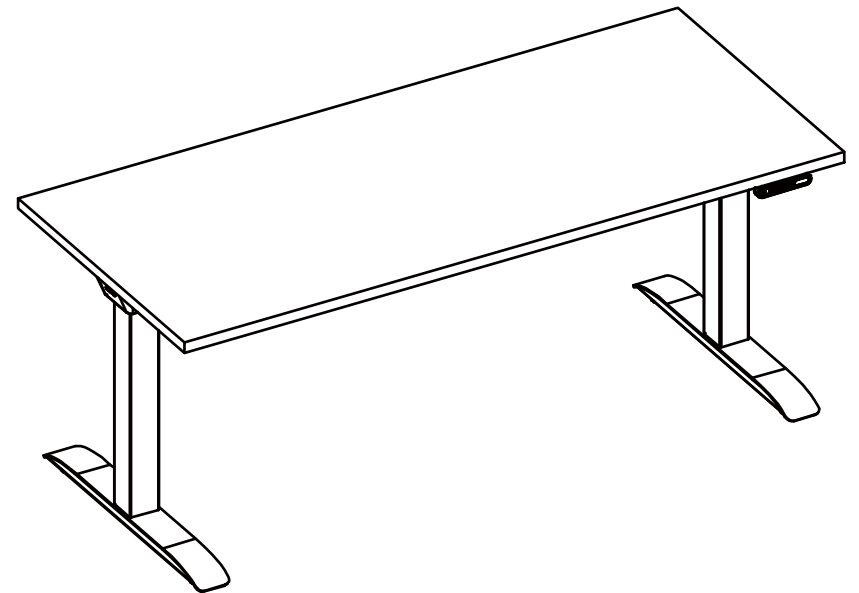

NOVAH System Technology Co.,Ltd.  
Tel: 400-115-1688  
Web: [www.novah.cc](http://www.novah.cc)  
Mail: [int@novah.cc](mailto:int@novah.cc)

**NOVAH**<sup>®</sup>

# Product Parts List



(Hexagon socket cylindrical head screw M6-16)



(Hexagon socket cylindrical head screw M6-12)



(Cross big flat head self-tapping screws ST5.5-20)



(Cross big flat head self-tapping screws ST3.5-16)



(Cross recessed pan head tapping screw M6-12)



(Cross recessed raised countersunk head tapping screw ST4.2\*45)



(Hexagon socket cylindrical head screw M6-12)  
(Optional ABS flip-top)



(Cross big flat head self-tapping screws ST5.5-20)  
(Optional ABS flip-top)

# Step 1

1. Place ① the lifting column and ④ undertable wireway as shown in the figure

2. Install ① the lifting column + ② bottom feet + ③ adjustable feet

## Sheet metal feet

(Hexagon socket pan head screw M6-16)

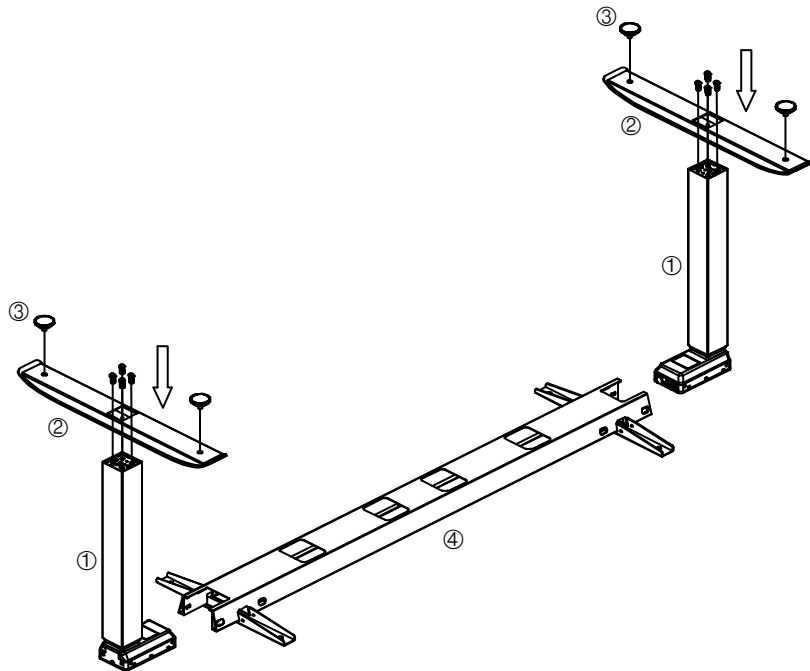

# Step 2

1. Install ① the lifting column and ④ undertable wireway (Hexagon socket cylindrical head screw M6-12)

2. Table stand turning over

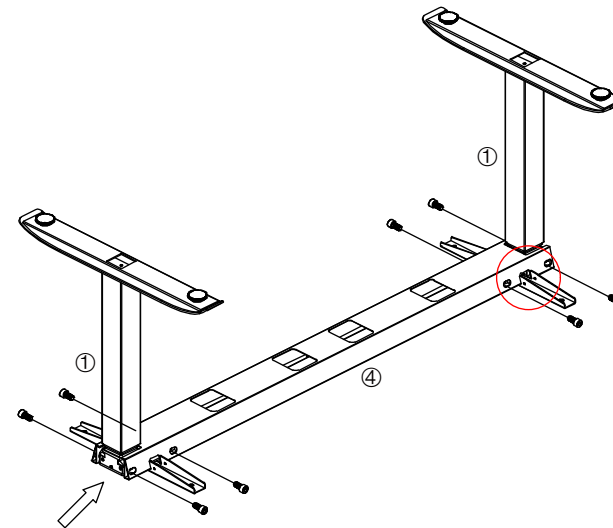

Note: Dyna\_Pro (LINAK) column mounting hole (Rose red)

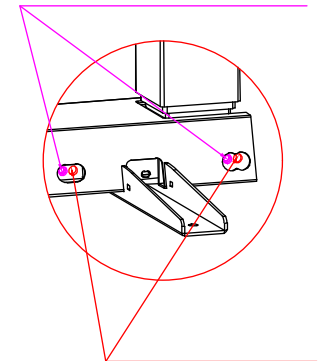

Note: Dyna\_Pro (JIECANG) column mounting hole (Red)

Note: Do not lock the screws on both sides of the lifting column, and the screw length can only be M6-12. Otherwise, it may cause damages to the motor and abnormal noise.

# Step 3

## 1. Install the cables of lifting table

The controller (rose red) is arranged between two holes with the plane downward; it is located in the direction of routing; convenient for connection with the table board Gyroscope (Cyan) is mounted on the side of the controller Motor wire (yellow) column (green) power cable (red) hand controller (blue) installed on the right

## 2. Install ⑤ the rubber gasket of table board

## 3. Install ⑥ the heightened pad

(Cross recessed big flat head tapping screw ST3.5\*12)

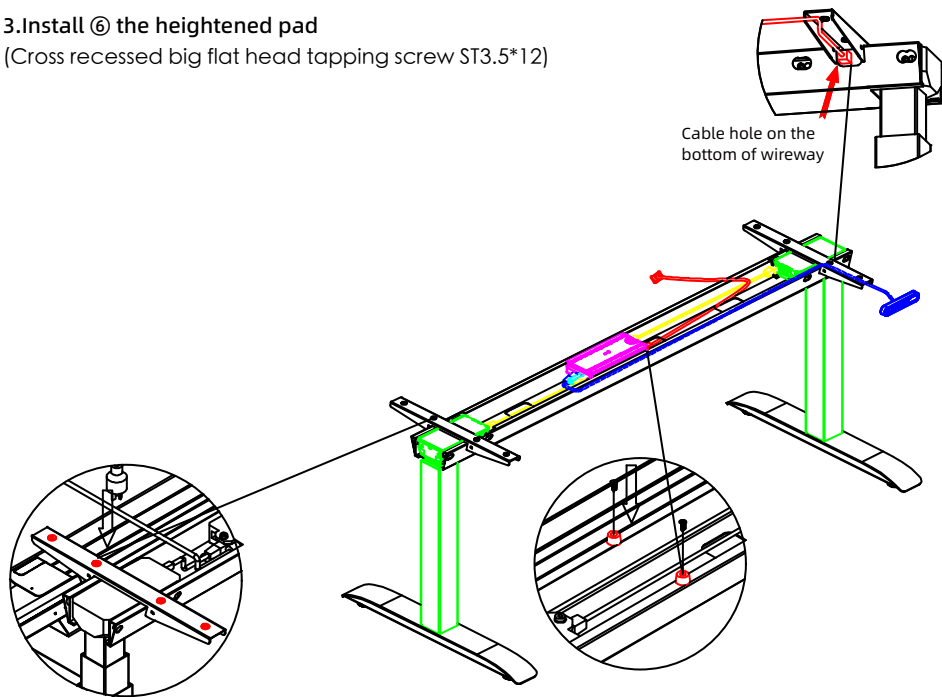

# Step 4

## 1. Routing Schematic Diagram

2. Reserve one position for 3-plug power of the lifting system of the workstation

3. Test if the lifting system runs normally and check if the circuits are plugged in firmly

4. Install the cover of undertable wireway ⑦ (ABS)(Fig.1)

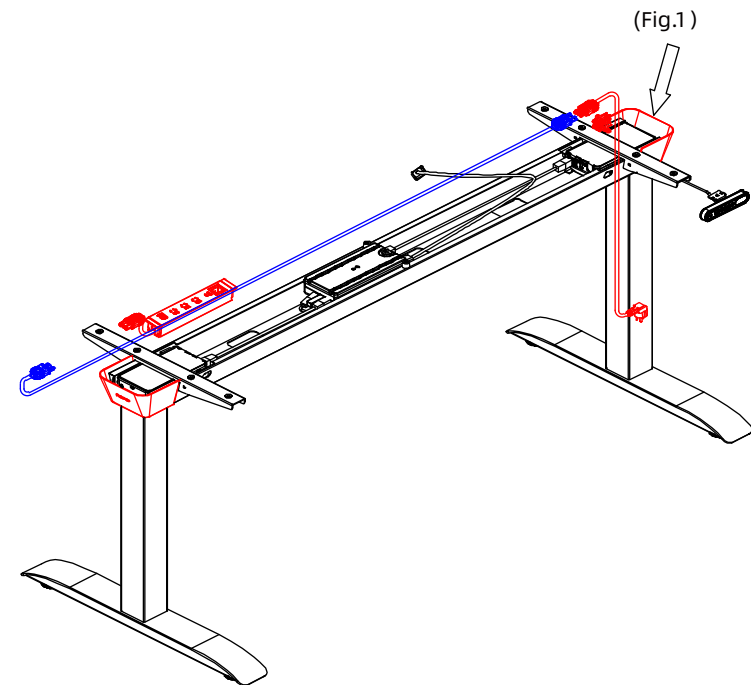

Note: Make sure the table frame is placed horizontally before locking the bolts on both sides of the lifting column, so as to avoid uneven table top after installation;

# Step 5

## 1. Install the table board

(Cross recessed pan head tapping screw ST5.5\*20)

The table board must be aligned with two ends of the table stand;

Table board clearance is 25mm in the direction of width

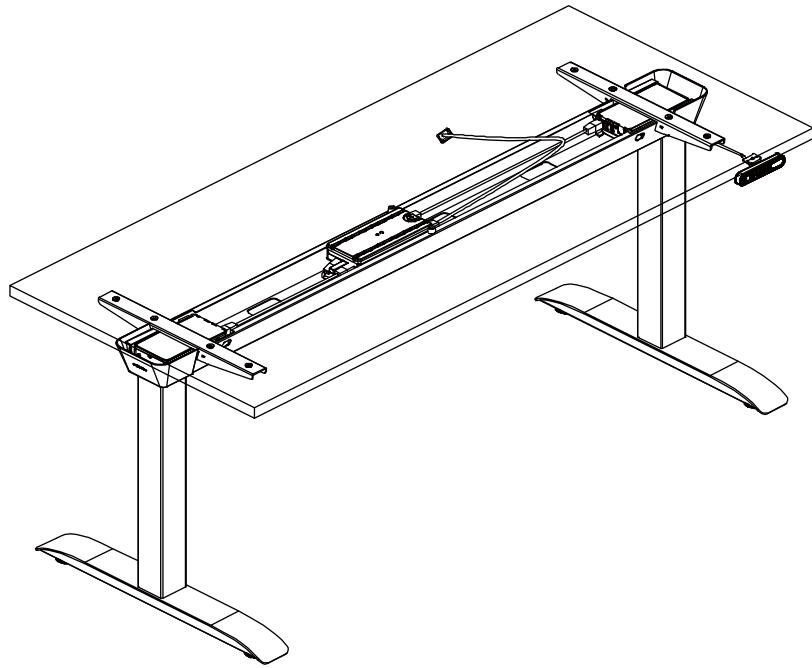

# Step 6

## 1. Install ⑧ the end cover of undertable wireway (ABS) (Fig.2)

## 3. Install the hand controller (Model DPF1C. The mounting screws of different hand controllers have different specifications)

with the cable attached to the support arm (Fig.3)

(DPF1C-Cross recessed pan head tapping screw ST3.5\*16)

(DPF1K-Cross recessed pan head tapping screw ST3.5\*16)

(DPG1C-Cross recessed raised countersunk head tapping screw ST3.5\*32)

## 3. Fix the controller on the table board (Fig.4)

(Cross recessed pan head tapping screw ST4.2\*45)

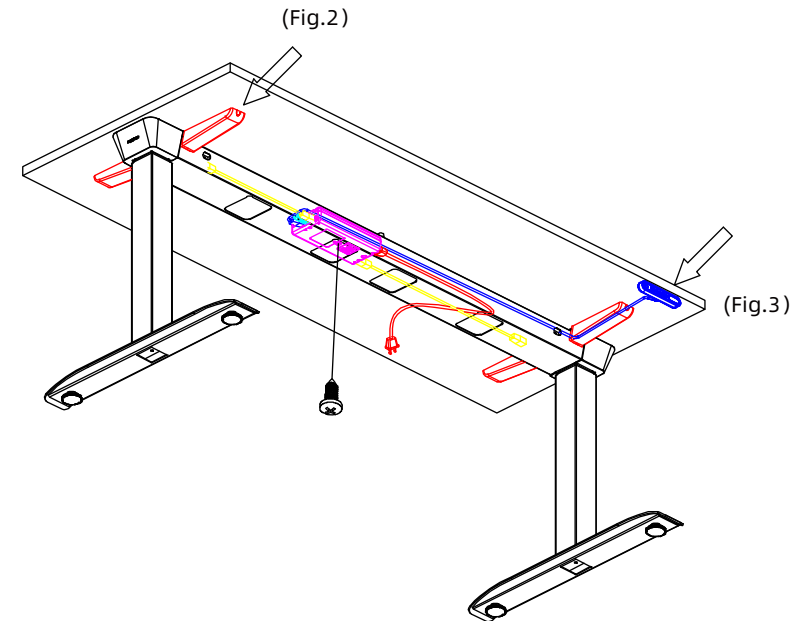

# Step 7

1.If ABS opening mode of table board is selected,  
steel wire box needs to be installed;The side of steel wire box  
faces towards the opening side of table board

(Cross recessed pan head tapping screw ST5.5\*20)

