

Dyna_Pro

Single-row one-piece screen

NOVAH[®]

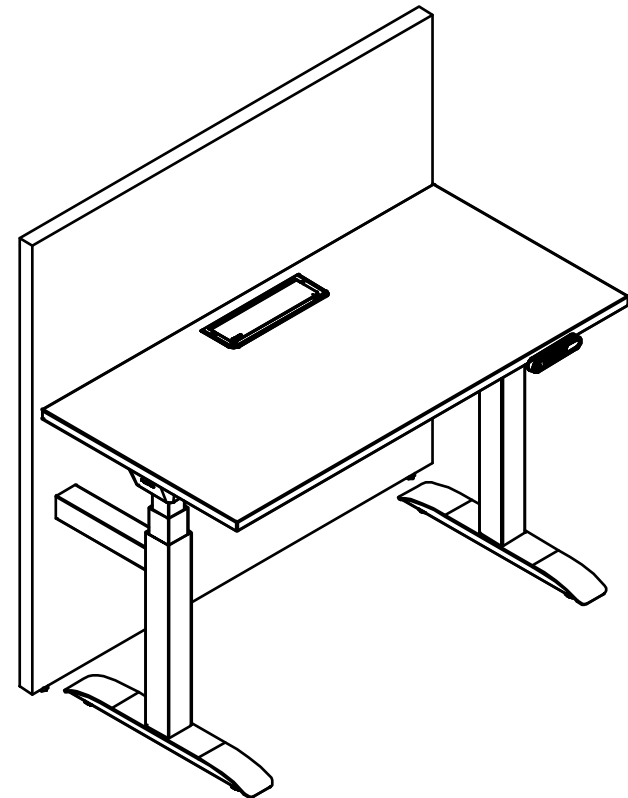

NOVAH System Technology Co.,Ltd.
Tel: 400-115-1688
Web: www.novah.cc
Mail: int@novah.cc

NOVAH[®]

Product Parts List



(Hexagon socket cylindrical head screw M8-20)



(Hexagon socket cylindrical head screw M6-16)



(Hexagon socket cylindrical head screw M6-14/Blackening)



(Hexagon socket cylindrical head screw M6-12)



(Cross recessed pan head tapping screw ST3.5-12)



(Cross recessed pan head tapping screw ST3.5-16)



(Cross recessed pan head tapping screw ST4.2-13)



(Cross recessed pan head tapping screw ST4-16)



(Cross recessed pan head tapping screw ST4.2-45)



(Cross big flat head self-tapping screws ST5.5-20)

Step 1

1. Place ① the lifting column and ④ undertable wireway as shown in the figure

2. Install ① the lifting column + ② bottom feet + ③ adjustable feet

Sheet metal feet

(Hexagon socket pan head screw M6-16)

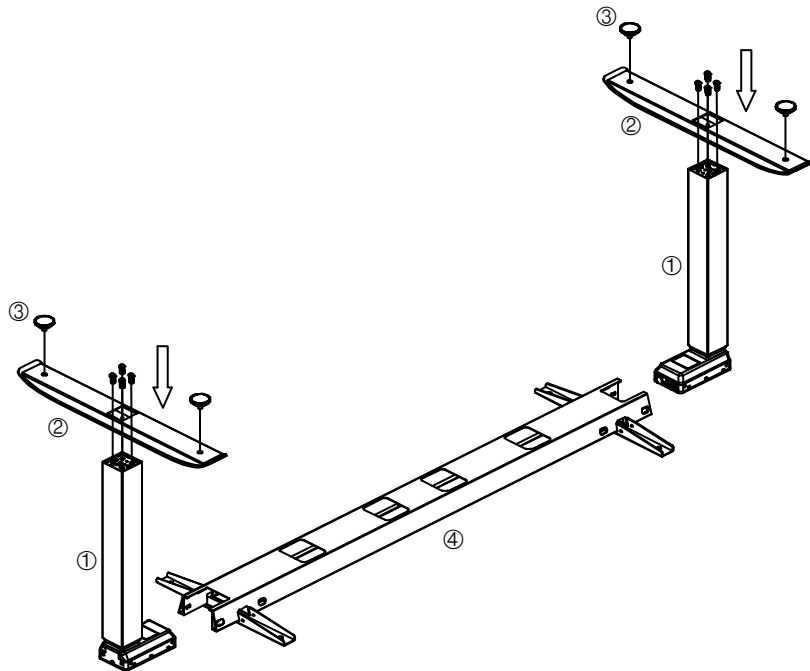

Step 2

1. Install ① the lifting column and ④ undertable wireway (Hexagon socket cylindrical head screw M6-12)

2. Install ① the lifting column and ⑤ undertable wireway (Hexagon socket cylindrical head screw M6-14/Blackening)
Pay attention to the direction of the cutouts of incoming line of connecting pipe.

3. Table stand turning over

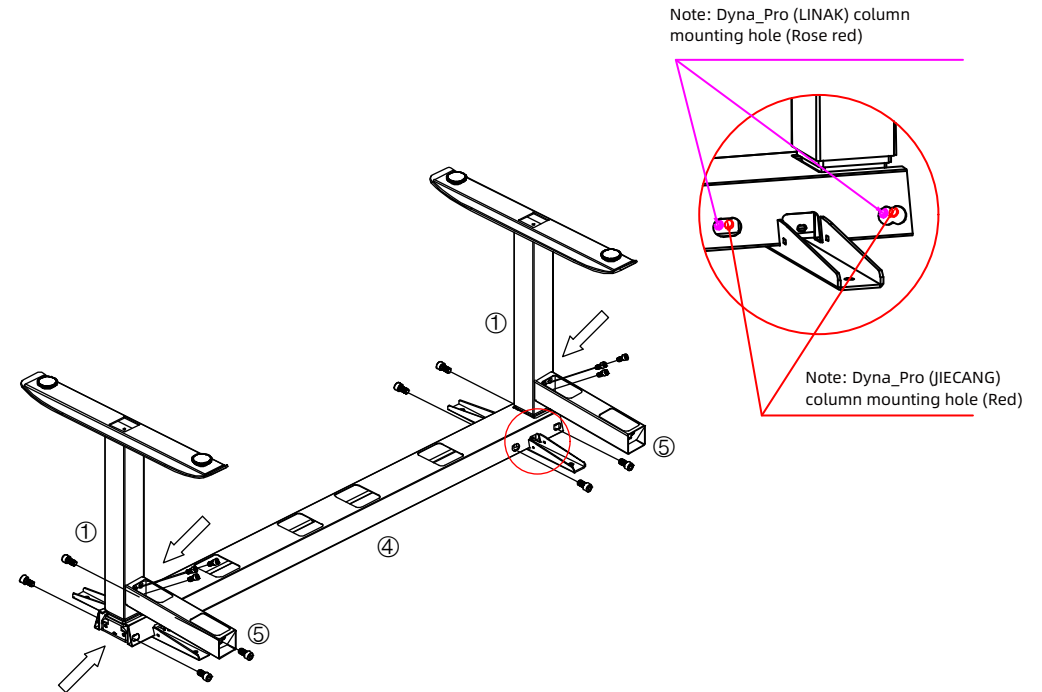

Note: Do not lock the screws on both sides of the lifting column, and the screw length can only be M6-12. Otherwise, it may cause damages to the motor and abnormal noise.

Step 3

1. Install ⑥ the rubber gasket of table board

2. Install ⑦ the heightened pad

(Cross recessed big flat head tapping screw ST3.5*12)

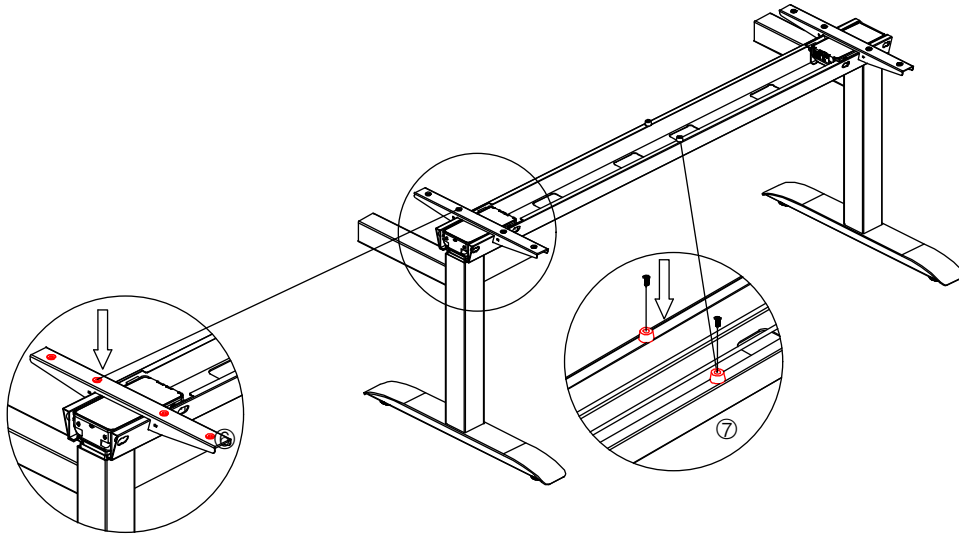

Step 4

Install the fittings between the screen and square pipe/round pipe screen

1. Place the screen and its fittings as shown in the figure

2. Install the screen fittings

(Cross big flat head self-tapping screws ST5.5-20)

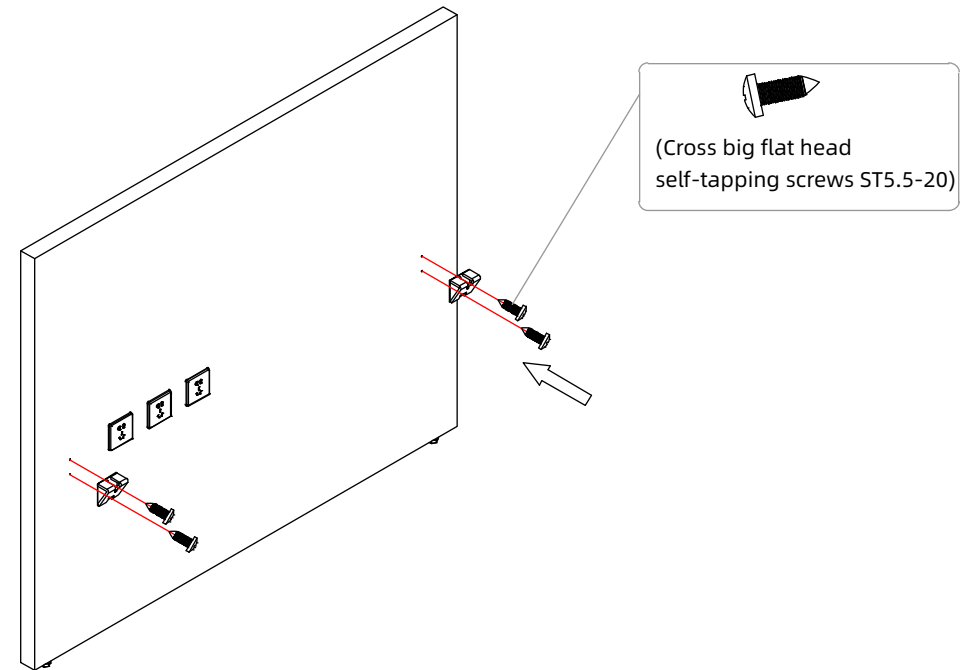

Note: Make sure the table frame is placed horizontally before locking the bolts on both sides of the lifting column, so as to avoid uneven table top after installation;

Step 5

1. Place the screen and height-adjustable table frame as shown in the figure

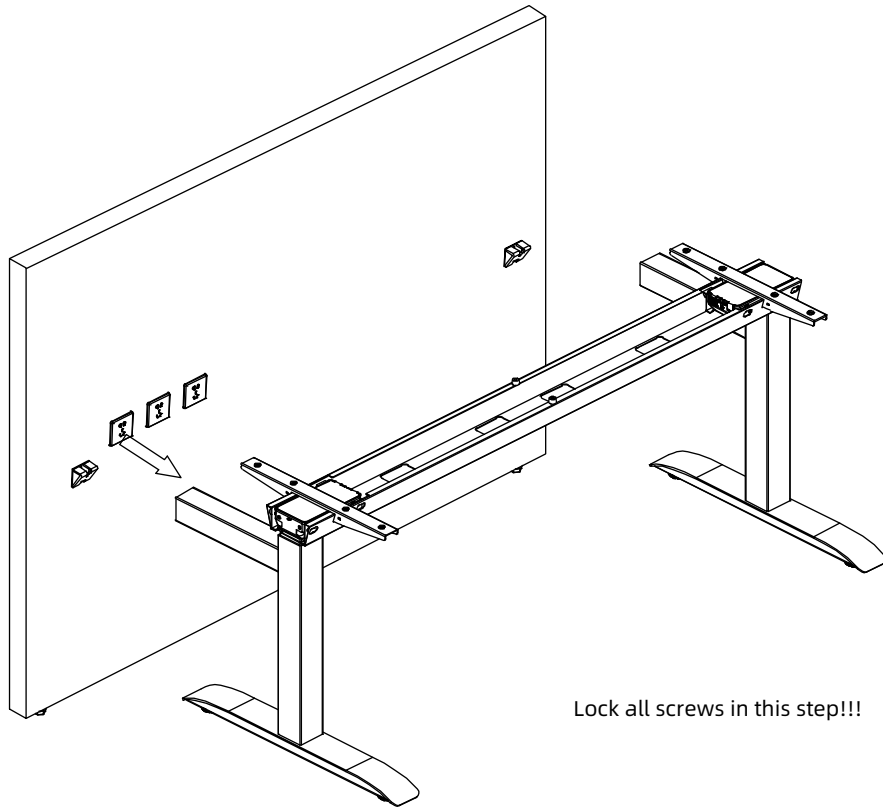

Lock all screws in this step!!!

Step 6

1. Install the height-adjustable table frame and screen
(Hexagon socket cylindrical head screw M8-20)

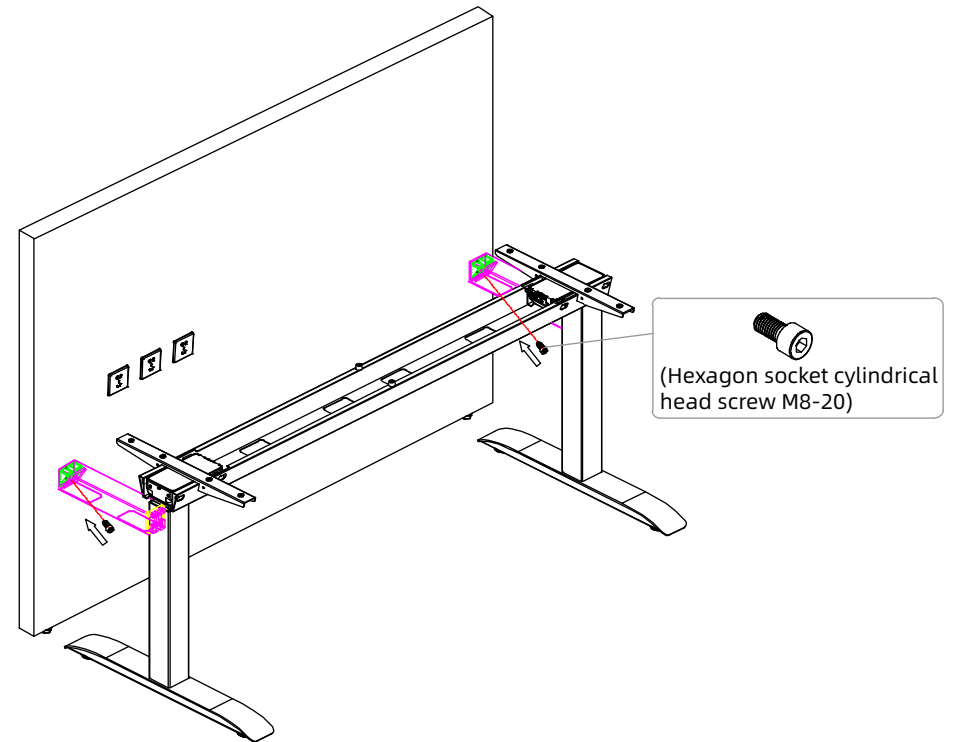

Step 7

1. Install the cables of lifting table

The controller (rose red) is arranged between two holes with the plane downward; it is located in the direction of routing; convenient for connection with the table board
Gyroscope (Cyan) is mounted on the side of the controller
Motor wire (yellow) column (green) power cable (red)
hand controller (blue) installed on the right

2. Install the cover of undertable wireway®(ABS)(Fig.1)

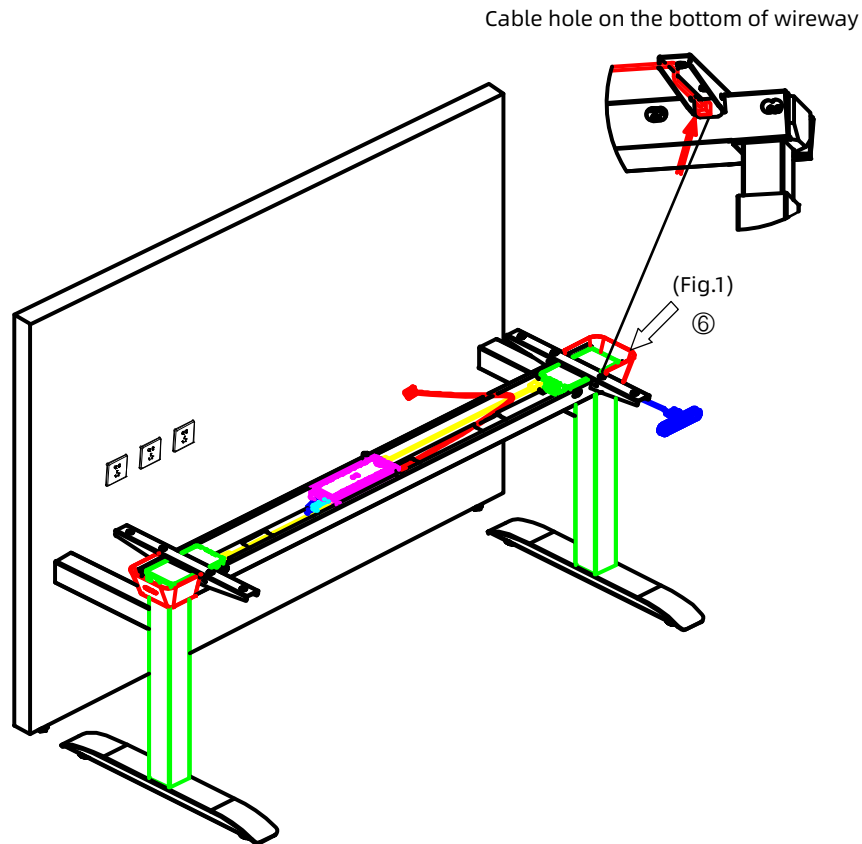

Step 8

Install the steel junction box of CEB socket

1. First thread the cables with quick connector through the opening as shown in the figure

2. Remove the plastic cap at two ends of the socket, and fix the socket onto the laminate with screws
(Cross recessed head tapping screw ST3.5-12)

3. Put the plastic cover on

4. Place the steel laminate with socket into the steel junction box as shown in the figure

5. Secure the bottom of steel box with screws
(Hexagon socket cylindrical head screw M6-12)

6. Steel junction box is installed

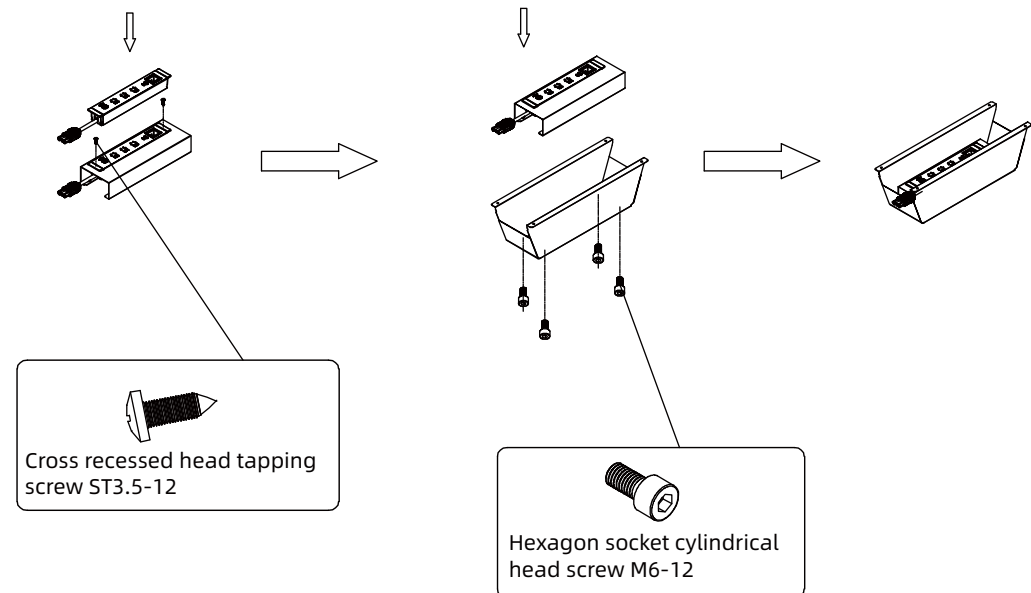

Step 9

Install the table board

1.As shown in the figure, a 15mm clearance is kept between the table board and screen; single side edge of table board is inward indented by 15mm

2.Install the table board and lifting desk frame

(Cross recessed big flat head tapping screw ST5.0-20)

3.Install the table board and steel junction box

(Cross recessed big flat head tapping screw ST5.0-20)

4.Install the single-clamshell cover

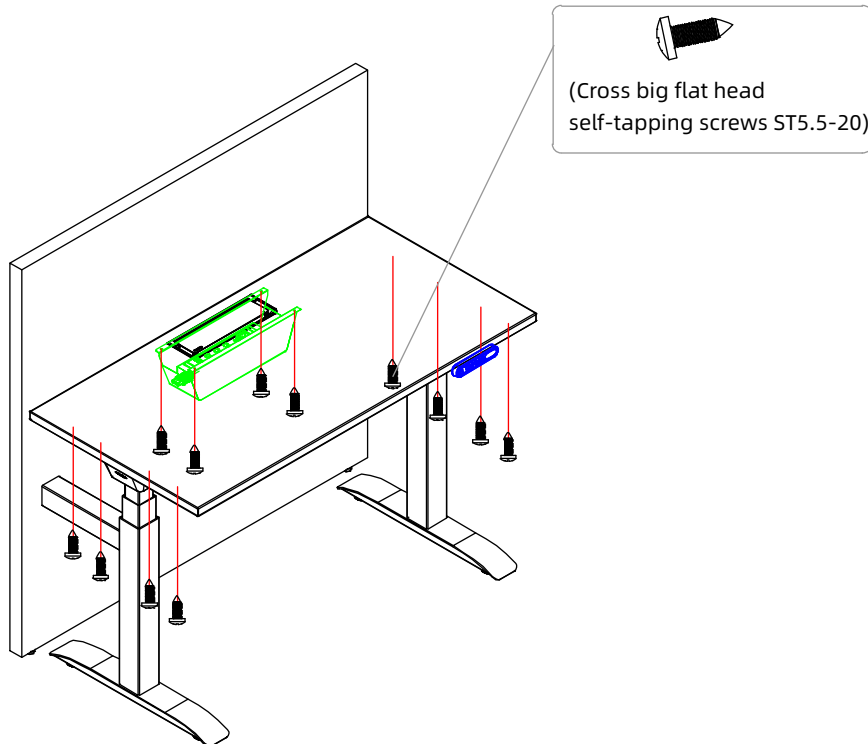

Step 10

Install the table board (in the following order)

1.As shown in the figure, a 15mm clearance is kept between the table board and screen,center them with the desk frame

2.Install the table board and lifting desk frame

(Cross recessed big flat head tapping screw ST5.0-20)

3.Then, lock the tank chain to the bottom of the table board in place

(Cross recessed head tapping screw ST 4.0-16)

4.Afterwards, fix the bottom of tank chain onto the side of the screen

connecting pipe with cross recessed self-drilling screws

(Cross recessed self-drilling screw ST 4.2-13)

5.Take off the buckle plate of tank chain, put the power cables in and finally put the buckle plate on

6.Install the end cover of support arm of wireway under the desk as described in the enlarged view below (Fig. 1)(Fig. 2)

7.Install the control box lock of lifting table under the desk board shown in the figure below (Fig. 3)

8.Install the hand controller.

(DPF1C_(Cross recessed pan head tapping screw 3.5*16)

(DPF1K_Cross recessed pan head tapping screw 3.5*16)

(DPG1C_Cross recessed raised countersunk head tapping screw 3.5*32)

with the cable attached to the support arm(Fig. 4)

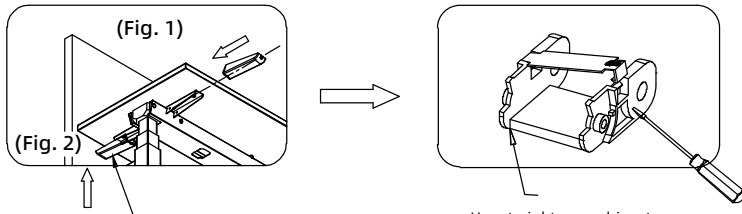

ABS support arm cover is flexible and slightly forced apart; seize one side, and then seize another side and then fasten them

Use straight screwdriver to pry open

Install the end cover of support arm of wireway under the desk

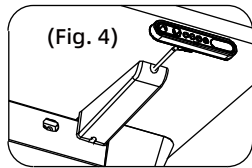

Install the hand controller

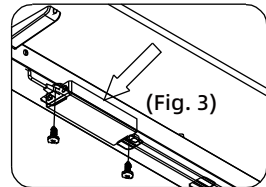

Install the power control box

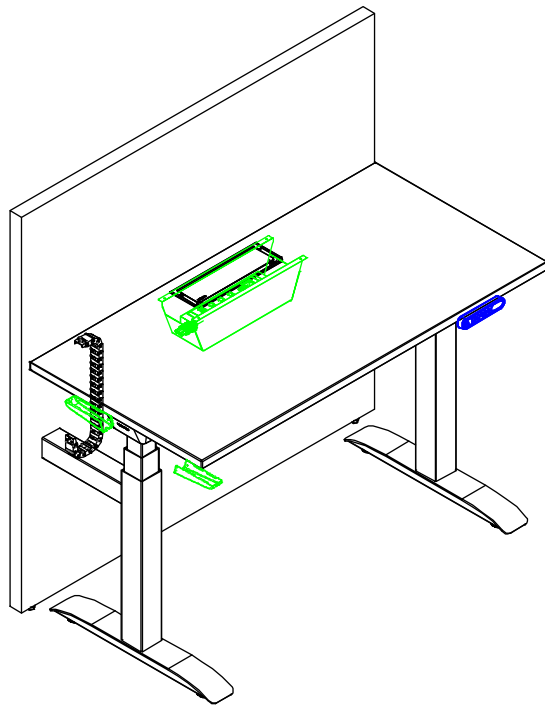

Step 11

1.The installation is complete

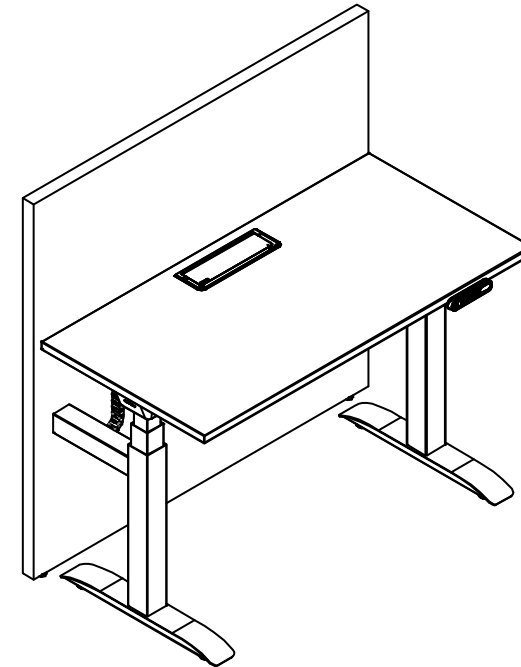

*Special note: Square columns and cylinders are installed in the same method